

AVG MAG-Drain

5000-200-AA

Magnetically operated zero air loss condensate drain

PRODUCT FEATURES

The AVG MAG-Drain removes condensate from compressed air filters. The operation is automatic and there is no compressed air lost during the condensate discharge cycle.

The AVG MAG-Drain uses magnetic forces to operate the direct acting valve assembly and is ideally suited in applications where power is not available, too expensive or not reliable.

The magnets have been specially selected to ensure that long lasting magnetism is guaranteed.



COMMERCIAL BENEFITS

- Extremely compact!
- Ultra lightweight, weighing only 0.95 kilo.
- Condensate discharge of all filters regardless of size or capacity.
- Clever servicing feature.
- Many compressed air filters are equipped with unreliable float type drains, replace them with a reliable AVG MAG-Drain.
- Personal branding opportunities are available.

TECHNICAL ADVANTAGES

- Zero air loss during the condensate discharge.
- No electricity required to operate the drain.
- Magnetically operated, long life magnets applied.
- Operating pressure range is 0 to 16 bar.
- Direct acting valve with FPM (Viton) seals.
- Robust corrosion resistant aluminium housing finished with an Electrophoretic coating.
- The direct acting valve is serviceable.
- Bottom (outlet) can be rotated 360 degrees for installation simplicity.

**No electricity
required!**

Opportunity!

Compressed air filters are generally supplied with inexpensive and unreliable float type drains, a decision based on cost. As a cutting-edge engineering company, Original AVG design and use only the best products, we recommend fitting a professional AVG MAG-Drain with every filter.

AVG MAG-Drain

5000-200-AA

Magnetically operated zero air loss condensate drain

DIMENSIONS (MM)

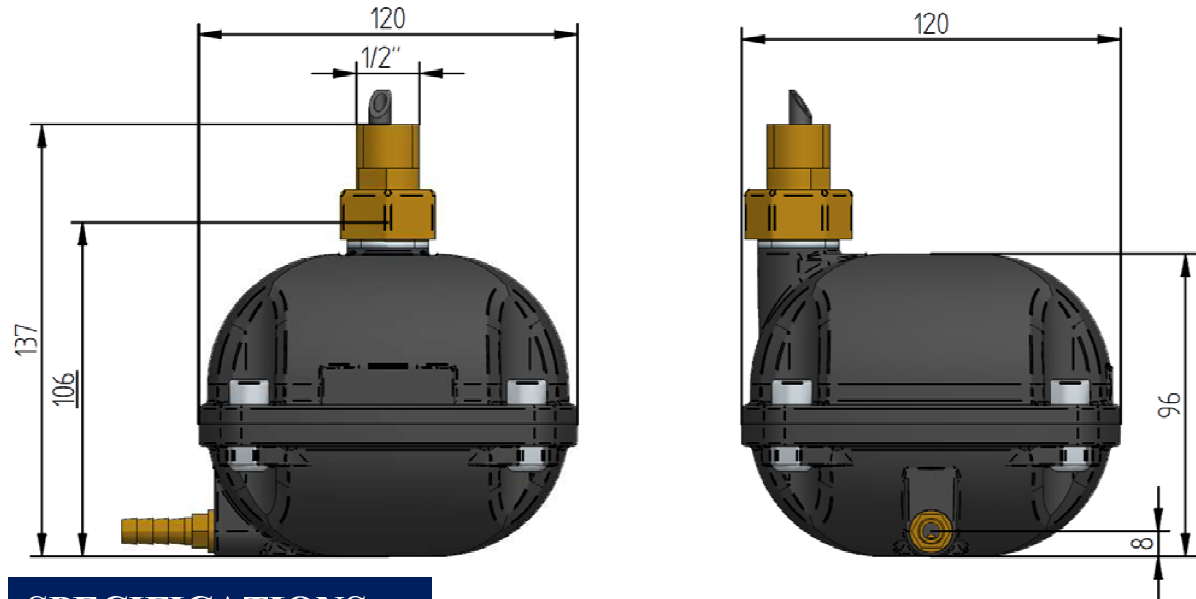

SPECIFICATIONS

Maximum drainage capacity	Unlimited filter draining capacity
Inlet connection	1/2" BSP or NPT (please specify)
Outlet connection	1/8"
Minimum system pressure	0 bar
Maximum system pressure	16 bar
Minimum medium temperature	2° C
Maximum medium temperature	50° C
Valve orifice	2.0 mm
Type of operating valve	Stainless steel direct acting valve assembly
Valve seals	Viton (FPM)
Housing material	Corrosion resistant Aluminium (EP coated)

Install an AVG MAG-Drain to ensure a reliable process of condensate draining on filters.

Original Ltd. is ISO 9001:2000

Nueair Engineered Products: Sales - Engineering - Representation: Nex Flow Air
 Cincinnati, Ohio 45215 www.nueair.com / www.nexflowUSA.com / nexflow.com □
sales@nueair.com PH: 513-761-1956 US Toll Free: 888-560-7027 □